

02<ROTAX EXHAUST SYSTEM>ROTAXマフラー関係

☆ROTAX 277用

●SIDE MOUNT タイプ

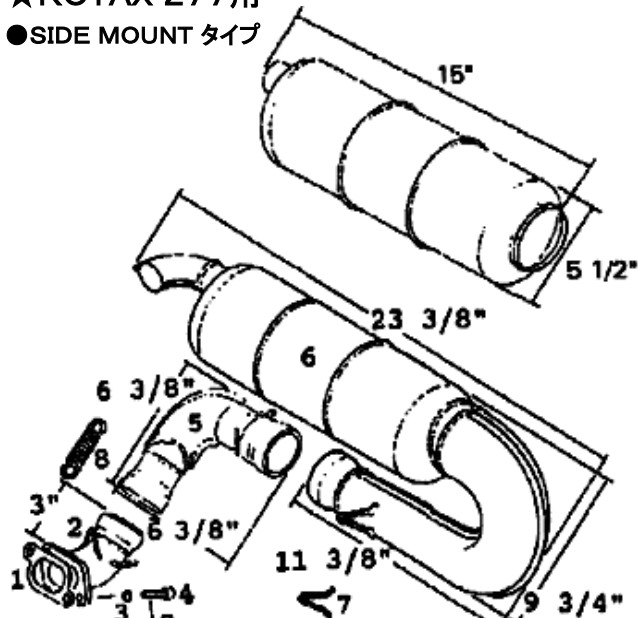

No.	商品	商品番号	数	価格
1	Gasket	831-847	1	¥ 1,200
2	Exhaust Socket Assy.	879-050	1	
3	Lock Washer	945-752	2	¥ 30
4	Cyl. Screw M8X30	840-991	2	¥ 190
5	Exhaust Elbow Assy.	973-095	1	
6	Muffler Assy.	973-198	1	¥ 57,570
7	Hook	853-355	3	¥ 250
8	Spring	938-795	6	¥ 440
9	ロックタイト#242(6mm)	67-242-06	1	¥ 1,070

●STANDARD タイプ

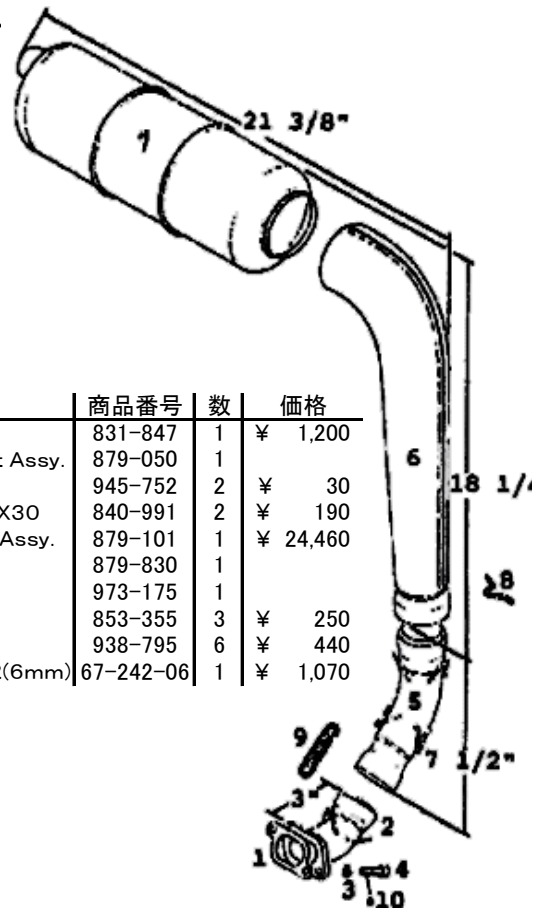

No.	商品	商品番号	数	価格
1	Gasket	831-847	1	¥ 1,200
2	Exhaust Socket Assy.	879-050	1	
3	Lock Washer	945-752	2	¥ 30
4	Cyl. Screw M8X30	840-991	2	¥ 190
5	Exhaust Elbow Assy.	879-101	1	¥ 24,460
6	Inlet Cone	879-830	1	
7	Muffler Assy.	973-175	1	
8	Hook	853-355	3	¥ 250
9	Spring	938-795	6	¥ 440
10	ロックタイト#242(6mm)	67-242-06	1	¥ 1,070

●STRAIGHT タイプ

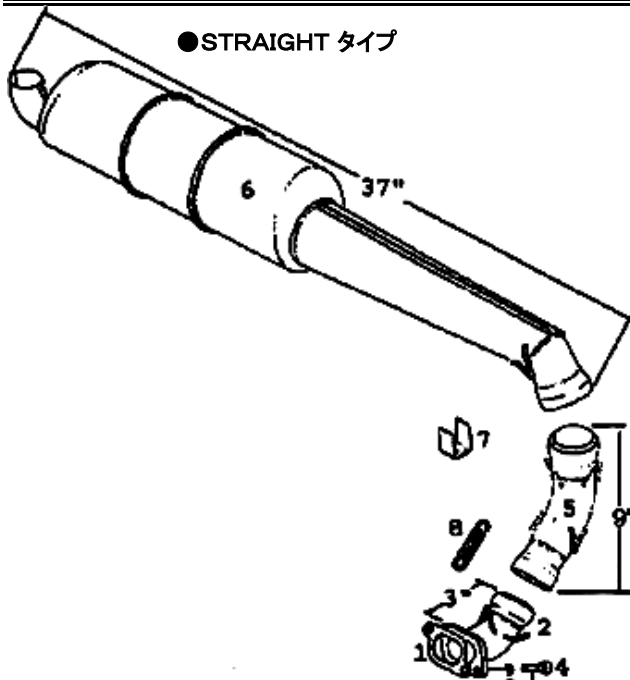

No.	商品	商品番号	数	価格
1	Gasket	831-847	1	¥ 1,200
2	Exhaust Socket Assy.	879-050	1	
3	Lock Washer	945-752	2	¥ 30
4	Cyl. Screw M8X30	840-991	2	¥ 190
5	Exhaust Elbow Assy.	879-101	1	¥ 24,460
6	Muffler Assy.	973-191	1	¥ 64,720
7	Bracket	951-150	2	¥ 1,540
8	Spring	938-795	6	¥ 440
9	ロックタイト#242(6mm)	67-242-06	1	¥ 1,070

●FISHER タイプ

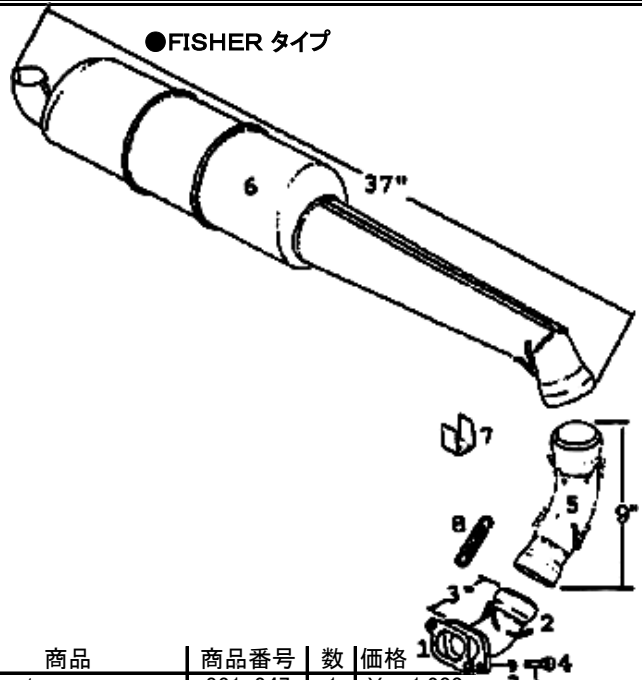

No.	商品	商品番号	数	価格
1	Gasket1	831-847	1	¥ 1,200
2	Exhaust Socket Manifold	879-054	1	
3	Lock Washer A8	945-752	2	¥ 30
4	Allen Screw M8X30	840-991	2	¥ 190
5	Exhaust Elbow Assy.	973-095	1	
5	Exhaust Elbow Assy.	879-101	1	¥ 24,460
6	Muffler Assy. ST 377	973-191	1	¥ 64,720
6	Muffler Assy. Fisher	973-203	1	
7	Bracket	951-150	2	¥ 1,540
8	Spring 66	938-795	6	¥ 440
9	Hook	853-355	3	¥ 250
10	ロックタイト#242(6mm)	67-242-06	1	¥ 1,070

※ロックタイト(ネジ弛み防止 #67-242-06 ¥1,070)

※各パーツ価格に関してはROTAX ENGINE関係価格一覧をご確認下さい。