



# Hirth-Information

Mitteilung-Nummer:

**0060**

Inhalt:

**Exhaust System Assemblies**  
(2-cylinder- and 4-cylinder engines)

Datum:

12.06.2002

## Basic System:

### Version 1 (Straight Version):

278 T13U

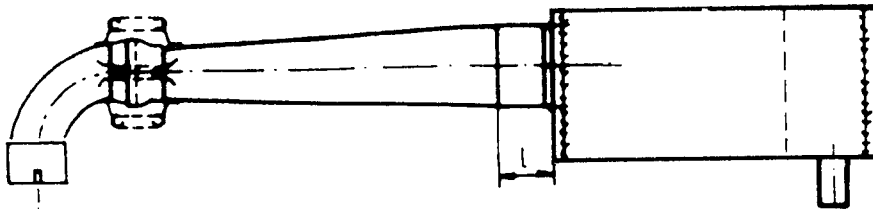

### Version 2 (90° Bow Version):

278 T14U

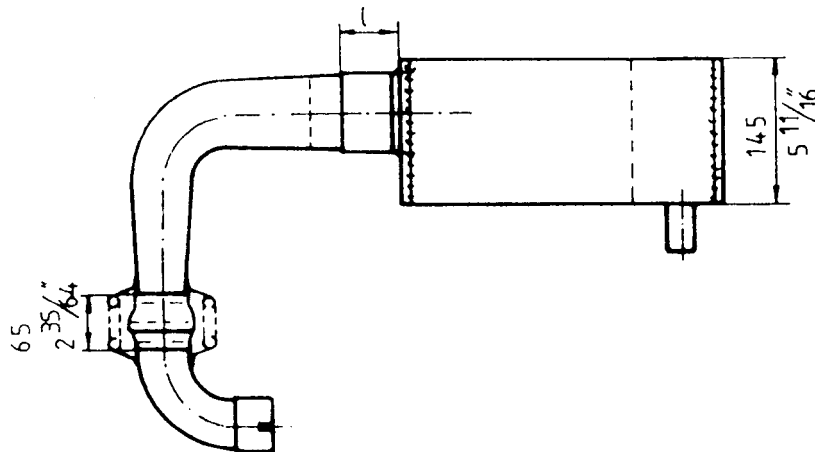

### Version 3 (180° Bow Version):

278 T15U

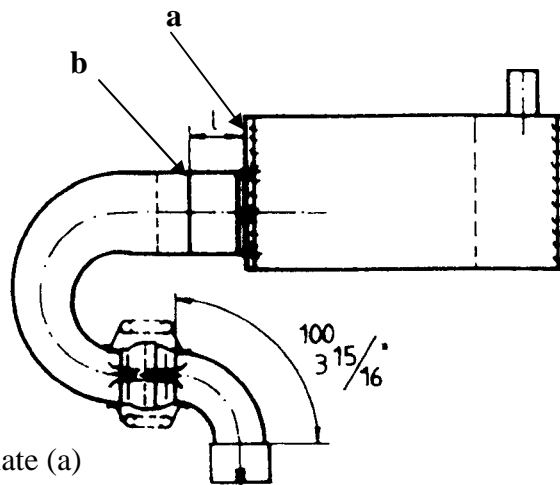

### Note:

The length „l“ is from the top plate (a) to the middle of the welding (b)

**278 T4U Silencer Complete**  
**278 E4U Weight : 3,2 kg**

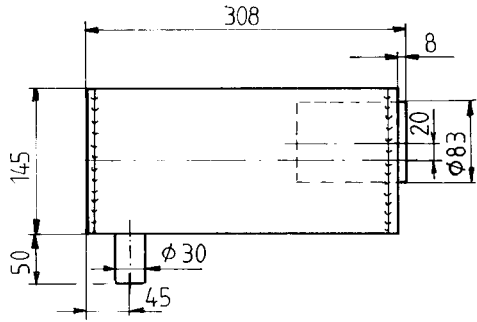

**278 E19U Connection Bow**  
**Weight : 0,6 kg**

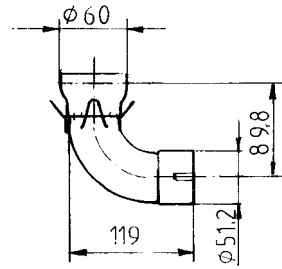

**278 T19U Diffuser Cone, Complete**  
**Weight: 1,5 kg**

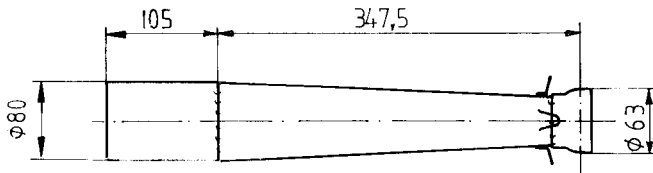

**278 T20U Bow 90°, complete**  
**Weight : 1,4 kg**

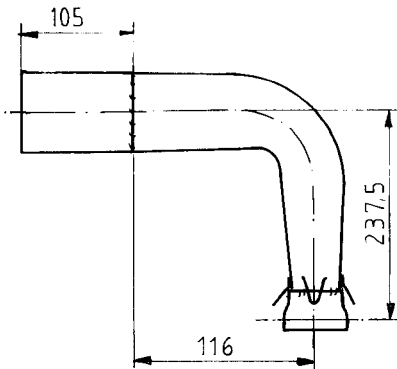

**268 A11U Clamp**

**278 T21U Bow 180°, complete**  
**Weight : 1,4 kg**

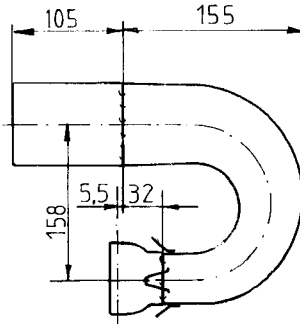

**F308 A4 Loop**

**278 H4U Ball Joint**  
**Weight : 0,26 kg**

**054.1**

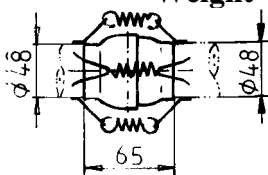

**Spring**

**278 R9U Rear Silencer**  
**Weight: 1,0 kg**

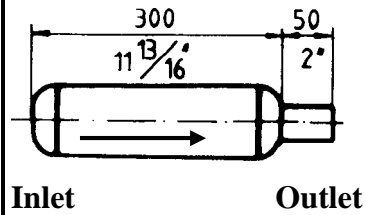

**358 G6 38x2,6 Bow**

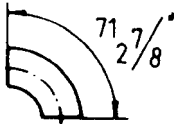

**F308 A5U Connection Bow**  
**Weight : 0,56 kg**

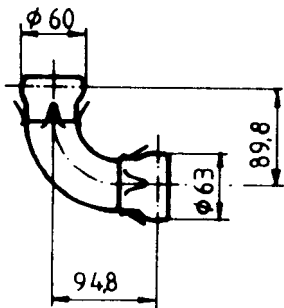

**F308 A7U Adaptor**  
**Weight : 0,23 kg**

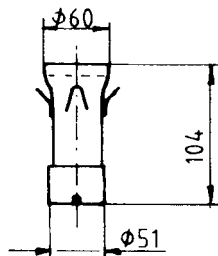

**For use on F 30 / 3002 / 3003 only!**

**F308 A1U Exhaust manifold 90°**  
**Weight : 0,63 kg**

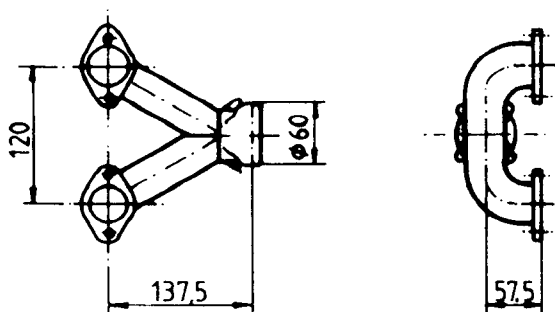

## Exhaust systems suitable to engine model.

### 2702 (1- Carburetor):

|    |        |    |          |                          |           |
|----|--------|----|----------|--------------------------|-----------|
|    |        | 1x | 278 E19U | Connection Bow           |           |
|    | Ver. 1 | 1x | 278 T19U | Diffuser cone (straight) | l = 10 mm |
| or | Ver. 2 | 1x | 278 T20U | Bow (90°)                | l = 10 mm |
| or | Ver. 3 | 1x | 278 T21U | Bow (180°)               | l = 10 mm |
|    |        | 1x | 278 E4U  | Silencer                 |           |

### 2703 (1-Carburetor, 2-Carburetor):

|    |        |    |          |                          |           |
|----|--------|----|----------|--------------------------|-----------|
|    |        | 1x | 278 E19U | Connection Bow           |           |
|    | Ver. 1 | 1x | 278 T19U | Diffuser cone (straight) | l = 30 mm |
| or | Ver. 2 | 1x | 278 T20U | Bow (90°)                | l = 30 mm |
| or | Ver. 3 | 1x | 278 T21U | Bow (180°)               | l = 30 mm |
|    |        | 1x | 278 E4U  | Silencer                 |           |

### 2704 (1-Carburetor, 2-Carburetor):

|    |        |    |          |                          |           |
|----|--------|----|----------|--------------------------|-----------|
|    |        | 1x | 278 E19U | Connection Bow           |           |
|    | Ver. 1 | 1x | 278 T19U | Diffuser cone (straight) | l = 55 mm |
| or | Ver. 2 | 1x | 278 T20U | Bow (90°)                | l = 94 mm |
| or | Ver. 3 | 1x | 278 T21U | Bow (180°)               | l = 98 mm |
|    |        | 1x | 278 T4U  | Silencer                 |           |

### 2704 (Fuel Injection):

|    |        |    |          |                          |           |
|----|--------|----|----------|--------------------------|-----------|
|    |        | 1x | 278 E19U | Connection Bow           |           |
|    | Ver. 1 | 1x | 278 T19U | Diffuser cone (straight) | l = 55 mm |
| or | Ver. 2 | 1x | 278 T20U | Bow (90°)                | l = 94 mm |
| or | Ver. 3 | 1x | 278 T21U | Bow (180°)               | l = 98 mm |
|    |        | 1x | 278 T4U  | Silencer                 |           |

### 2706 (2-Carburetor, Fuel Injection):

|    |        |    |          |                          |          |
|----|--------|----|----------|--------------------------|----------|
|    |        | 1x | 278 E19U | Connection Bow           |          |
|    | Ver. 1 | 1x | 278 T19U | Diffuser cone (straight) | l = 0 mm |
| or | Ver. 2 | 1x | 278 T20U | Bow (90°)                | l = 0 mm |
| or | Ver. 3 | 1x | 278 T21U | Bow (180°)               | l = 0 mm |
|    |        | 1x | 278 T4U  | Silencer                 |          |

### 3202 (2-Carburetor, Fuel Injection):

|    |        |    |          |                          |           |
|----|--------|----|----------|--------------------------|-----------|
|    |        | 1x | 278 E19U | Connection Bow           |           |
|    | Ver. 1 | 1x | 278 T19U | Diffuser cone (straight) | l = 90 mm |
| or | Ver. 2 | 1x | 278 T20U | Bow (90°)                | l = 90 mm |
| or | Ver. 3 | 1x | 278 T21U | Bow (180°)               | l = 90 mm |
|    |        | 1x | 278 E4U  | Silencer                 |           |

### 3203 (2-Carburetor, Fuel Injection):

|    |        |    |          |                          |          |
|----|--------|----|----------|--------------------------|----------|
|    |        | 1x | 278 E19U | Connection Bow           |          |
|    | Ver. 1 | 1x | 278 T19U | Diffuser cone (straight) | l = 0 mm |
| or | Ver. 2 | 1x | 278 T20U | Bow (90°)                | l = 0 mm |
| or | Ver. 3 | 1x | 278 T21U | Bow (180°)               | l = 0 mm |
|    |        | 1x | 278 T4U  | Silencer                 |          |

**F 30 K / 3002 V (2-Carburetor):**

|    |        |    |          |                          |           |
|----|--------|----|----------|--------------------------|-----------|
|    |        | 2x | 278 E19U | Connection Bow           |           |
|    | Ver. 1 | 2x | 278 T19U | Diffuser cone (straight) | l = 28 mm |
| or | Ver. 2 | 2x | 278 T20U | Bow (90°)                | l = 28 mm |
| or | Ver. 3 | 2x | 278 T21U | Bow (180°)               | l = 28 mm |
|    |        | 2x | 278 T4U  | Silencer                 |           |

**F 30 U / 3003 E (2-Carburetor):**

|    |        |    |          |                          |          |
|----|--------|----|----------|--------------------------|----------|
|    |        | 2x | 278 E19U | Connection Bow           |          |
|    | Ver. 1 | 2x | 278 T19U | Diffuser cone (straight) | l = 0 mm |
| or | Ver. 2 | 2x | 278 T20U | Bow (90°)                | l = 0 mm |
| or | Ver. 3 | 2x | 278 T21U | Bow (180°)               | l = 0 mm |
|    |        | 2x | 278 T4U  | Silencer                 |          |

**F 30 E / 3002 E (Fuel Injection):**

|    |        |    |          |                          |           |
|----|--------|----|----------|--------------------------|-----------|
|    |        | 2x | 278 E19U | Connection Bow           |           |
|    | Ver. 1 | 2x | 278 T19U | Diffuser cone (straight) | l = 28 mm |
| or | Ver. 2 | 2x | 278 T20U | Bow (90°)                | l = 28 mm |
| or | Ver. 3 | 2x | 278 T21U | Bow (180°)               | l = 28 mm |
|    |        | 2x | 278 T4U  | Silencer                 |           |

**F 30 ES / 3003 E (Fuel Injection):**

|    |        |    |          |                          |          |
|----|--------|----|----------|--------------------------|----------|
|    |        | 2x | 278 E19U | Connection Bow           |          |
|    | Ver. 1 | 2x | 278 T19U | Diffuser cone (straight) | l = 0 mm |
| or | Ver. 2 | 2x | 278 T20U | Bow (90°)                | l = 0 mm |
| or | Ver. 3 | 2x | 278 T21U | Bow (180°)               | l = 0 mm |
|    |        | 2x | 278 T4U  | Silencer                 |          |

**H 32 (Fuel Injection):**

|    |        |    |          |                          |          |
|----|--------|----|----------|--------------------------|----------|
|    |        | 1x | 278 E19U | Connection Bow           |          |
|    | Ver. 1 | 1x | 278 T19U | Diffuser cone (straight) | l = 0 mm |
| or | Ver. 2 | 1x | 278 T20U | Bow (90°)                | l = 0 mm |
| or | Ver. 3 | 1x | 278 T21U | Bow (180°)               | l = 0 mm |
|    |        | 1x | 278 T4U  | Silencer                 |          |

Please note, the performance specified for an engine will not be guaranteed if an exhaust variant is used which differs from the three basic versions (page one). As a result from such modifications, it is possible that damage may occur to the engine. There will be no liability by Goebler-Hirthmotoren to provide any warranty for any malfunction or damage incurred by such modifications.

The length I = 0 mm stated for the 2706 engine (both carburettors and fuel injection models), the F30U / 3003 (dual carburettor) and the F30ES / 3003 E (fuel injection) models, illustrates either the 278T19U, 278T20U or the 278T21U diffuser cone must be slipped completely into the silencer, 278E4U or 278T4U. The lengths that differ from a null measurement refer to the measurement as stated within the sketches identified with "I".